

# ROXIE

## FOLLOWSPOT / PROJECTEUR DE POURSUITE

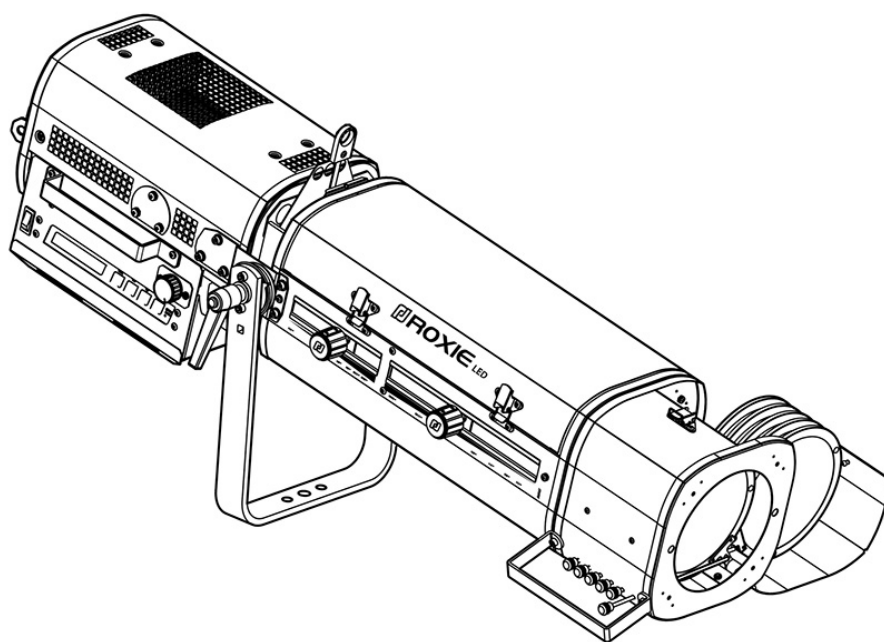

	Standard Standard	North American Nord-Américain
REF	1166	1166C

### 300W LED FOLLOWSPOT / PROJECTEUR DE POURSUITE LED 300W

ROXIE - 1166 / C - Version V2

VALIDATION: 31/03/17

**DN41087001-A**



**ROBERT JULIAT**

# Table of Contents

<b>1</b>	<b>User's instructions</b>	<b>1</b>
<b>2</b>	<b>Presentation</b>	<b>2</b>
2.1	<b>Functions</b>	<b>2</b>
2.2	<b>Identification label</b>	<b>3</b>
2.3	<b>Accessories included</b>	<b>3</b>
2.4	<b>Optional accessories</b>	<b>4</b>
<b>3</b>	<b>Set-up</b>	<b>5</b>
3.1	<b>Mechanics</b>	<b>5</b>
3.1.1	<i>Operating positions</i>	<b>5</b>
3.1.2	<i>Minimum distance between a flammable material and the lighting unit</i>	<b>5</b>
3.1.3	<i>Instructions for use</i>	<b>5</b>
3.1.4	<i>Lifting</i>	<b>5</b>
3.1.5	<i>Stand set-up</i>	<b>6</b>
3.2	<b>Electrical information</b>	<b>6</b>
3.2.1	<i>LED source</i>	<b>6</b>
3.2.2	<i>Power supply</i>	<b>6</b>
3.2.3	<i>Data</i>	<b>8</b>
3.3	<b>Accessories</b>	<b>9</b>
3.3.1	<i>Iris</i>	<b>9</b>
3.3.2	<i>Gobo holder</i>	<b>9</b>
3.3.3	<i>Colour changer unit - push-pull</i>	<b>9</b>
<b>4</b>	<b>Operations</b>	<b>10</b>
4.1	<b>Light intensity</b>	<b>10</b>
4.1.1	<i>Range</i>	<b>10</b>
4.1.2	<i>Control</i>	<b>10</b>
4.1.3	<i>Parameters</i>	<b>10</b>
4.2	<b>Beam size adjustment</b>	<b>12</b>
4.2.1	<i>Range</i>	<b>12</b>
4.2.2	<i>Control</i>	<b>12</b>
4.3	<b>Strobe</b>	<b>12</b>
4.3.1	<i>Range</i>	<b>12</b>
4.3.2	<i>Control</i>	<b>13</b>
4.4	<b>Pan / Tilt</b>	<b>13</b>
4.4.1	<i>Range</i>	<b>13</b>
4.4.2	<i>Control</i>	<b>13</b>
4.5	<b>Iris</b>	<b>14</b>
4.5.1	<i>Range</i>	<b>14</b>
4.5.2	<i>Control</i>	<b>14</b>
4.6	<b>Gobo</b>	<b>14</b>
4.6.1	<i>Range</i>	<b>14</b>
4.7	<b>Colour</b>	<b>14</b>
4.7.1	<i>Range</i>	<b>14</b>
<b>5</b>	<b>DMX Controls</b>	<b>15</b>
5.1	<b>Control board</b>	<b>15</b>
5.1.1	<i>Display and Controls</i>	<b>15</b>
5.1.2	<i>Menus and parameters</i>	<b>15</b>
5.1.3	<i>DMX Chart</i>	<b>15</b>
5.1.4	<i>Reset</i>	<b>16</b>
5.1.5	<i>Feedback information</i>	<b>16</b>
<b>6</b>	<b>Service</b>	<b>16</b>
6.1	<b>Preventive maintenance</b>	<b>16</b>
6.1.1	<i>Frequency</i>	<b>16</b>
6.1.2	<i>General cleaning</i>	<b>16</b>
6.1.3	<i>General visual check</i>	<b>16</b>
6.1.4	<i>LED source</i>	<b>16</b>
6.1.5	<i>Optics</i>	<b>17</b>
6.1.6	<i>Analysis</i>	<b>17</b>
6.1.7	<i>LED reaction according to LED temperature</i>	<b>17</b>
6.1.8	<i>Thermal protection</i>	<b>17</b>
6.1.9	<i>Adjusting the maximum light output level</i>	<b>17</b>
6.1.10	<i>Exploded view / Spare parts list</i>	<b>17</b>
<b>7</b>	<b>Troubleshooting</b>	<b>18</b>
7.1	<b>General information</b>	<b>18</b>

# 1 User's instructions

## GENERAL INSTRUCTIONS

1. Not for residential use.
2. **These fixtures must only be serviced by a qualified technician.**
3. In addition to the instructions indicated on this page, relevant health and safety requirements of the appropriate EU Directives must be adhered to at all times.
4. This fixture is in compliance with section 17 - Lighting appliance for theatre stages, television, cinema and photograph studios. Standards NF EN 60598-1, NF EN 60598-2-17, NF EN 61000-3-2 Classe C and NF EN 61000-3-3 Classe C.
5. This fixture is rated as IP20, and is for indoor use only.

## FIXTURE

6. Ensure fixture is correctly mounted on an appropriate support.
7. Protection screens and lenses must be replaced in the event of any damage, such as cracks or deep scratches, since these might reduce performance.
8. When hung or flown the fixture must be secured by an additional hanging accessory (such as a safety cable or bond) of suitable length.
9. Safety bonds or cables must be securely attached to the back of the fixture and be as short as possible, or rolled up as necessary, to minimise travel distance should the fixture be dislodged.
10. Movable accessories (scroller, etc.) must also be secured with a suitable safety cable or bond at the front of the fixture.
11. The combined weight of both the fixture and the accessories must be considered when choosing the load-bearing capability of safety cable or bond.
12. Do not open lighting fixture when the source is on.
13. **WARNING:** LED source become hot during use. Allow fixture to cool before servicing.
14. Do not tamper with design of fixture nor any of its safety features.
15. Tighten electrical mains cable connections regularly and replace with one of identical specification if damaged.
16. Use only with correct power supply.

## VENTILATION

17. Keep well away from flammable material.
18. Not for outdoor use. Do not cover. Do not permit fixture to get wet.
19. To avoid overheating, do not obstruct air vents.
20. Ensure any cooling fans are in correct working order. If fans are not working, turn fixture off immediately and service as necessary.

## CLEANING

21. Do not touch LED source with fingers.
22. Clean all optical parts with alcohol-based cleaner.
23. Clean all filters regularly.

## POWER SUPPLY

24. Disconnect from the mains before servicing.
25. Mains connection only. Do not connect to "electronic output" such as dimmer.
26. Not for outdoor use. Do not cover.
27. Ensure power supply circuit breakers, always remain accessible.

## PLEASE NOTE

These products have been built to conform to European standards relating to professional lighting equipment. Any modification made to our products will void the manufacturers' warranty.

## 2 Presentation

### 2.1 Functions

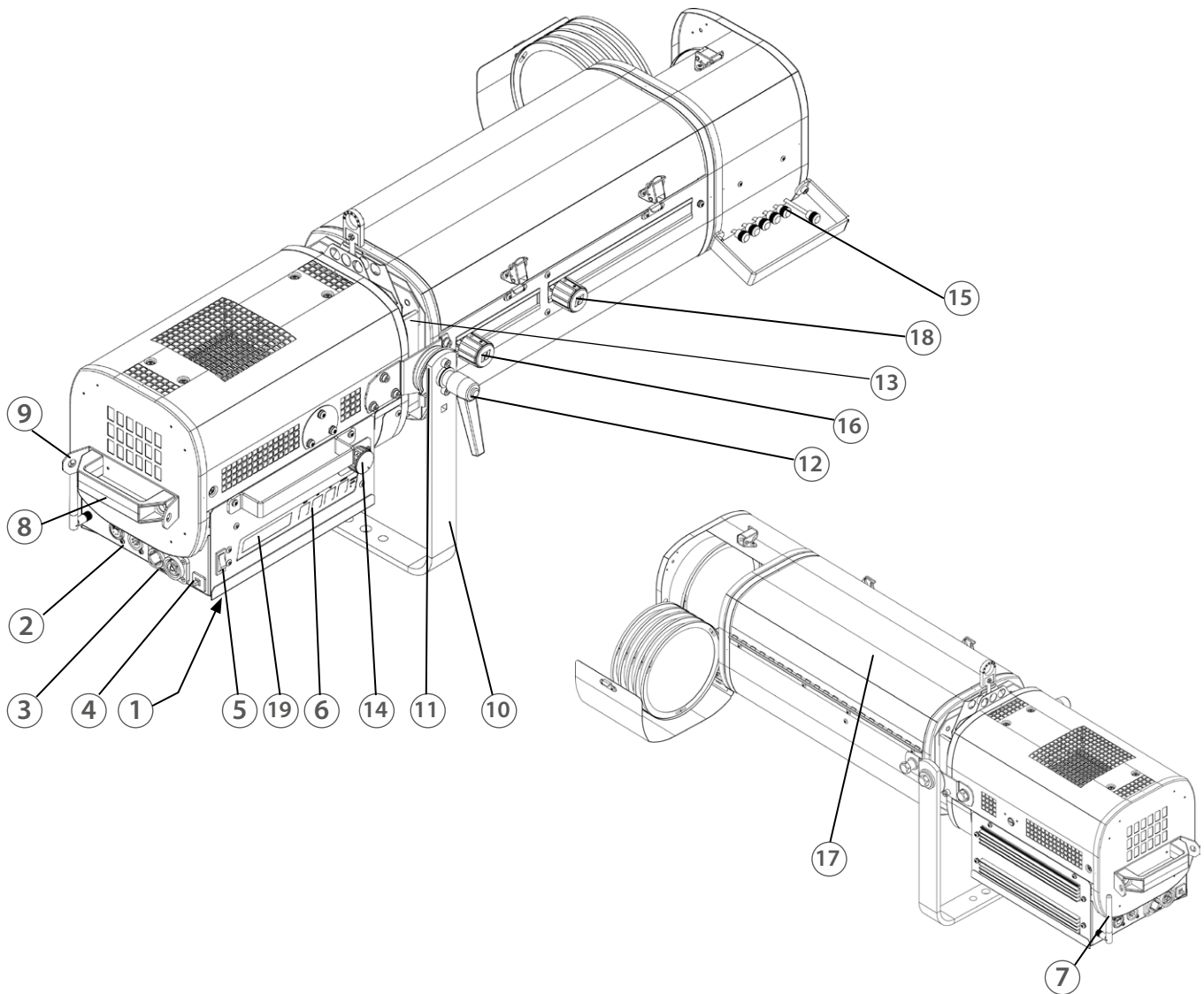

Functions	
<ul style="list-style-type: none"><li>1. Identification plate</li><li>2. Data connectors (IN and OUT)</li><li>3. Power connectors (IN and OUT)</li><li>4. Thermal breaker</li><li>5. Power switch</li><li>6. Control board</li><li>7. Wireless DMX antenna (option)</li><li>8. Handle</li><li>9. Safety cable attachment point</li><li>10. Yoke</li><li>11. Tilt index</li></ul>	<ul style="list-style-type: none"><li>12. Tilt locking handle</li><li>13. Gate: slots for gobo holder and/or iris</li><li>14. Dimmer rotary knob</li><li>15. Colour changer</li><li>16. Focus adjustment</li><li>17. Lens tube access</li><li>18. Zoom adjustment</li><li>19. Display screen</li></ul>

## 2.2 Identification label

**Units :**  
 - Dimensions = metre (m) millimetre (mm).  
 - Weight = kilogram (kg).  
 - Intensity = Ampere (A).  
 - Voltage = Volt (V).  
 - Frequency = Hertz (Hz).  
 - Temperature = degree Celsius (°C).

Description	
	<ol style="list-style-type: none"> <li>1. MOD. : Model</li> <li>2. VERS. : Version</li> <li>3. U : Nominal voltage input (V)</li> <li>4. I : Nominal intensity (A)</li> <li>5. P : Maximum power input (W)</li> <li>6. IP : International Protection Rating</li> <li>7. t°a : Maximum ambient temperature (°C)</li> <li>8. t°c : Maximum external temperature of the unit (°C)</li> <li>9. Net weight (kg)</li> <li>10. Minimum distance between a flammable material and the lighting unit (m)</li> <li>11. Colour temperature version :                      CW = Cool White                      WW = Warm White                      NDW = Neutral Daylight White</li> <li>12. Serial number</li> <li>13. Replace broken glass</li> <li>14. Class 1 product label</li> <li>15. Read manual first label</li> <li>16. European conformity label</li> <li>17. WEEE directive label</li> </ol>

## 2.3 Accessories included

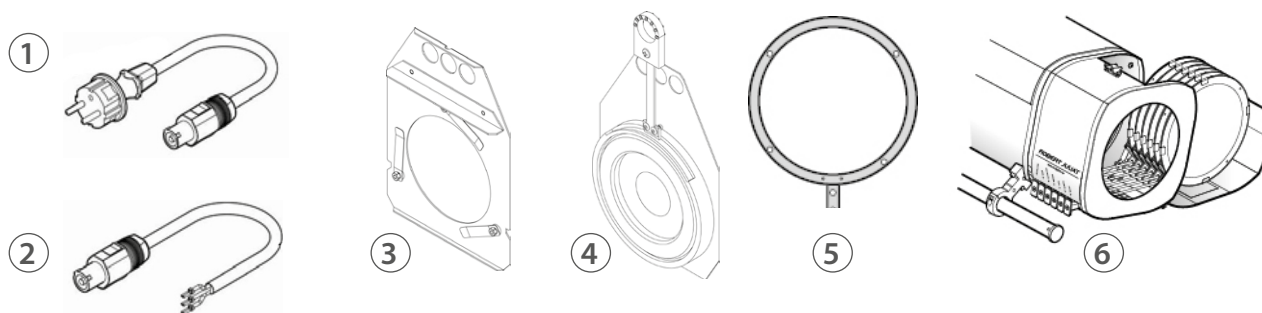

	Reference	Description
1	CAL03	Power cable with CEE 7/7 type in connectors (standard version)
2	CAL04	UL/CSA power cable without connector (North-American version)
3	SGUX	Universal "A" size gobo holder (metal, glass or frosted glass)
4	IS750	Full closing iris with holder
5	PF1114	Ø165 mm metal filter holder
6	M165TP	6-way "push/pull" colour changer

2.4 Optional accessories

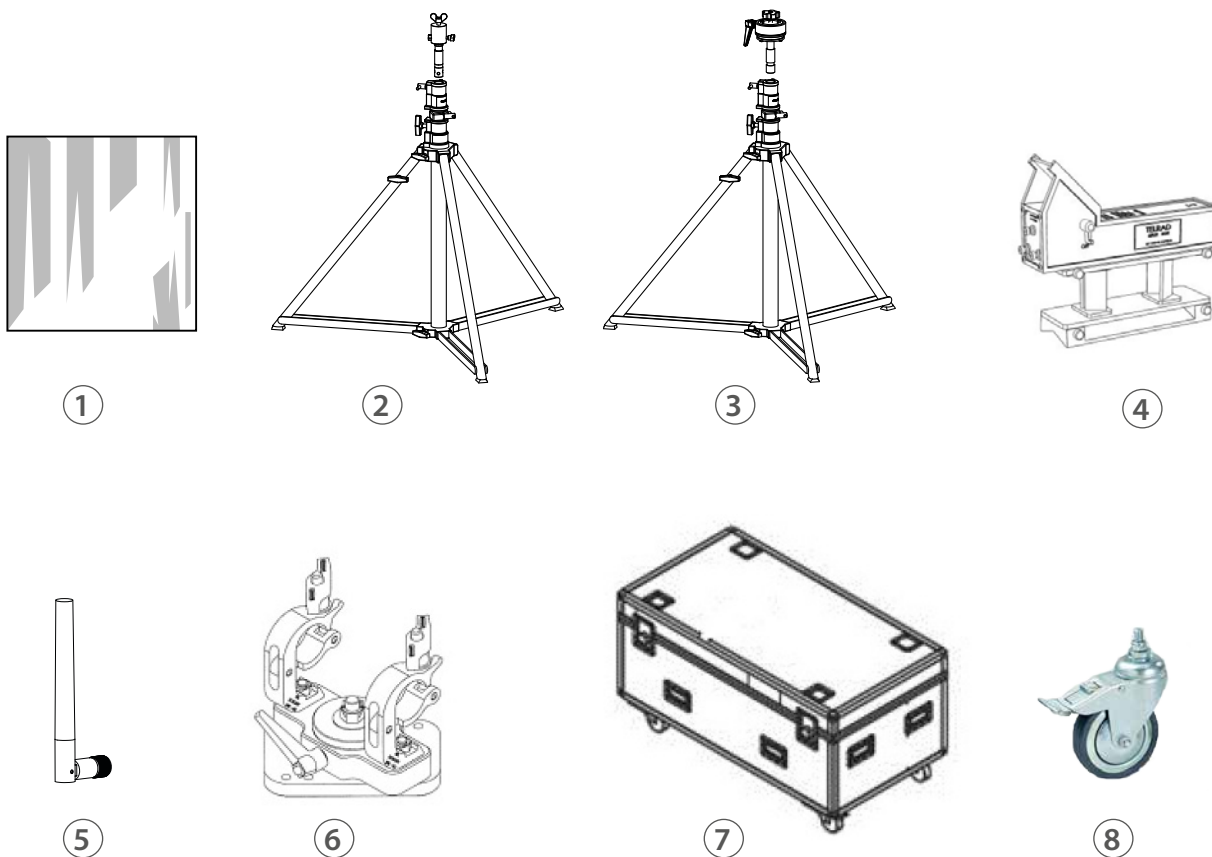

	Reference	Description
1	VD120	120 x 120 mm frosted glass
2	GT800	Tripod stand GT800 - SWL: 40 kg max. height 1550 mm
3	GT1000	Tripod stand GT1000 - SWL: 40 kg max. height 1550 mm
4	Kit TELRAD	Followspot sight with riser
5	W-DMX/ZF2	W-DMX Wireless DMX antenna
6	T4000	Followspot mount for 50 mm diam. pipe (suspension or overhead) - SWL: 100 kg
7	FC1124/S	Transport flight-case for ultra compact range followspots
8	W/GT800	Set of 3 wheels for GT800/1000 stands

# 3 Set-up



## 3.1 Mechanics

### 3.1.1 Operating positions

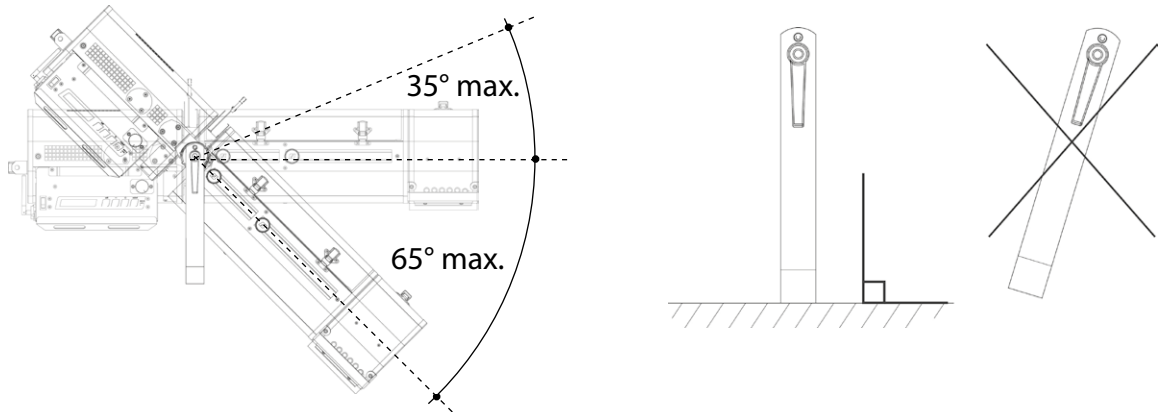

### 3.1.2 Minimum distance between a flammable material and the lighting unit

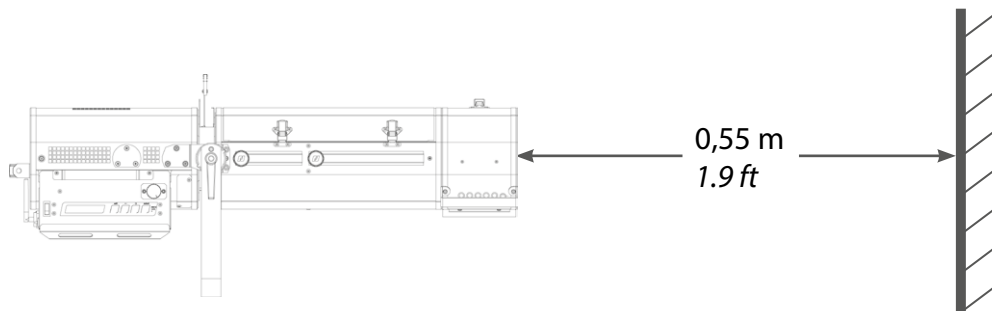

### 3.1.3 Instructions for use

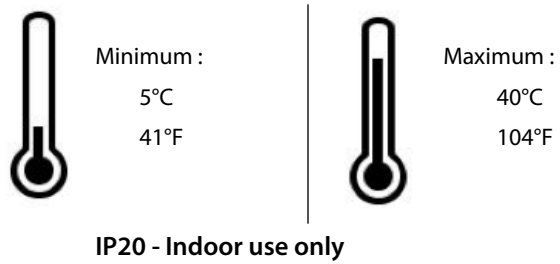

### 3.1.4 Lifting

- Net weight: 20 Kg (44,1 lbs).

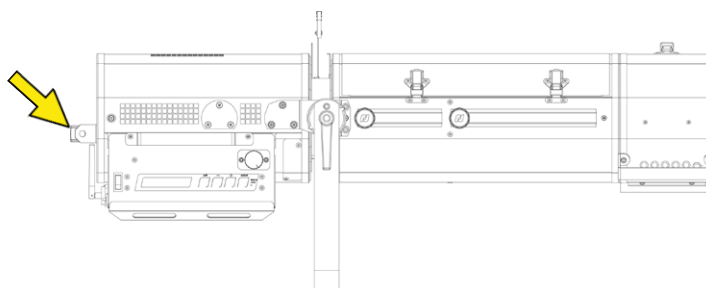

### 3.1.5 Stand set-up

- Compatible stands : GT800 & GT1000  
Please refer to the relevant user manual for further details.

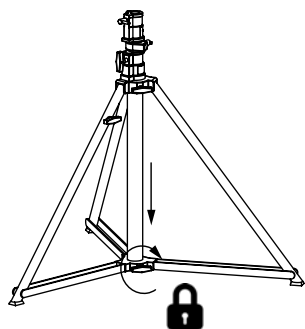

↓ MAX  
40kgs/88lbs

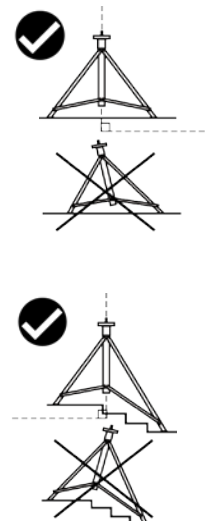
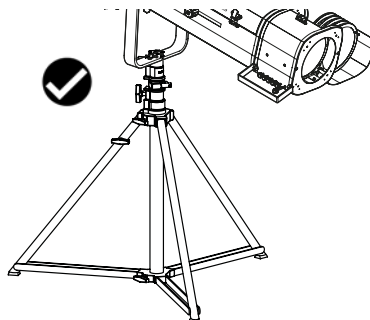



### 3.2 Electrical information

#### 3.2.1 LED source



**Never touch or scratch the LED surface.**  
Cf. EN-19, 6.1.4 LED cleaning procedure if cleaning is necessary.

#### 3.2.2 Power supply

Power supply			
Voltage	Frequency	Input power	Connectors
90 → 264 V	47-63 Hz	1,4 A / 350 W @ 230V 2,5 A / 350 W @ 120V 3 A / 350 W @ 100V	Neutrik powerCON TRUE1 Input : ref. NAC3PX (max. 20A)
 <ul style="list-style-type: none"> <li>• Class 1 product. <b>This luminaire must be earthed.</b></li> <li>• Must be connected directly to AC power. <b>Do not connect to dimmer power.</b></li> <li>• Automatic power detection</li> <li>• <b>On the same breaker, maximum of: 10 units (230V) / 5 units (110V)</b></li> </ul>			
<p>Daisy chain:</p>  <p>Maximum : 10 units (230V) &amp; 5 units (110V)</p>			

**Power cable**

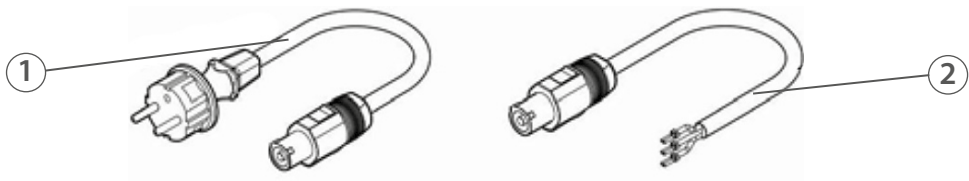

Power cable		Connector	Mains plug	Cable type	Cable length	Wiring
1	Standard version	Neutrik® powerCON TRUE1 NAC3FX	CEE7/7	3G1.5 H07RNF	3 m 9.8 ft	Live: Brown Neutral: Blue Ground: Yellow/Green
2	North American version		-	14AWG SJ TYPE (UL/CSA)	1.5 m 4.9 ft	Live: Black Neutral: White Ground: Green

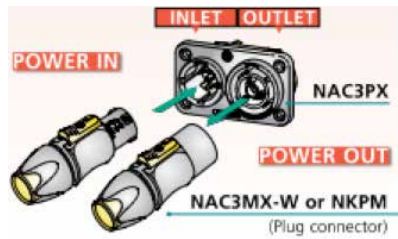

**Power on**

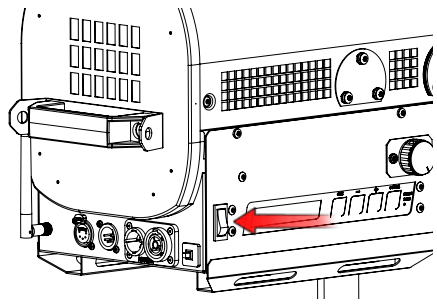

3.2.3 Data

DATA		
Protocol	Input connector	Output connector
USITT DMX 512-A	XLR 5-pin	XLR 5-pin

DATA connectors			
PIN #	DMX	Description	
1	Shielding	Foil & Braided Shield	
2	DMX (-)	1 <sup>st</sup> conductor of 1 <sup>st</sup> twisted pair	
3	DMX (+)	2 <sup>nd</sup> conductor of 1 <sup>st</sup> twisted pair	
4	Not used	1 <sup>st</sup> conductor of 2 <sup>nd</sup> twisted pair	
5	Not used	2 <sup>nd</sup> conductor of 2 <sup>nd</sup> twisted pair	

**Integrated terminal plug:**  
 If no XLR connector is detected on DMX OUT connector, a 120Ω terminal plug is automatically activated. Additional terminal plug on the last unit is not necessary.

Wireless DMX option	
<ul style="list-style-type: none"> <li>• Protocol: Wireless Solution W-DMX™</li> <li>• Refer to the OEM User’s manual for general recommendations and use of the transmitter: <a href="http://www.wirelessdmx.com">http://www.wirelessdmx.com</a></li> <li>• The antenna must be clearly visible from the transmitter</li> <li>• Refer to RJ-LED Software manual for activation procedure (page EN-15)</li> <li>• <b>Do not connect a DMX IN data cable in case of wireless DMX use</b></li> </ul>	
<p><b>DMX mode:</b> The first unit receives the DMX signal via the wireless network, then all the other units are connected on the first one via DMX data cable.</p>	
<p>Maximum : 32 units</p>	

3.3.1 Iris

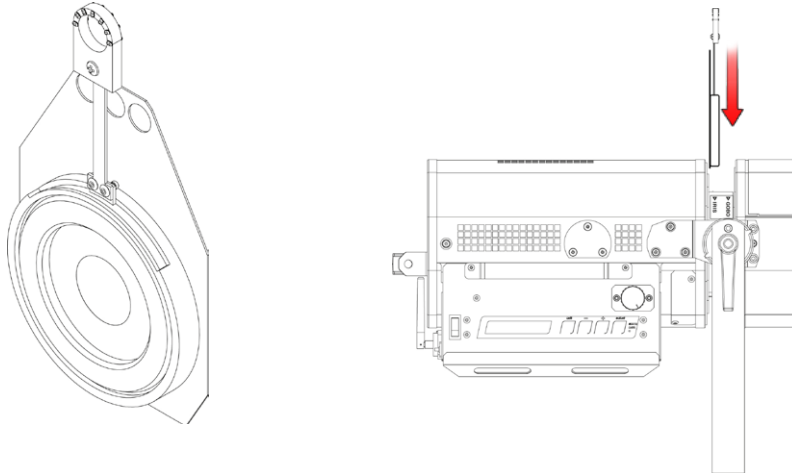

3.3.2 Gobo holder

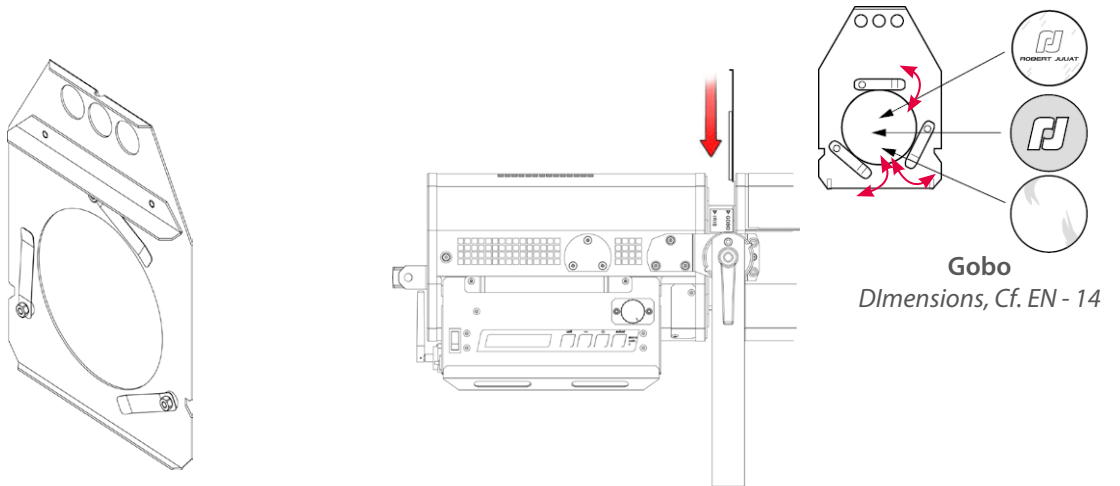

3.3.3 Colour changer unit - push-pull

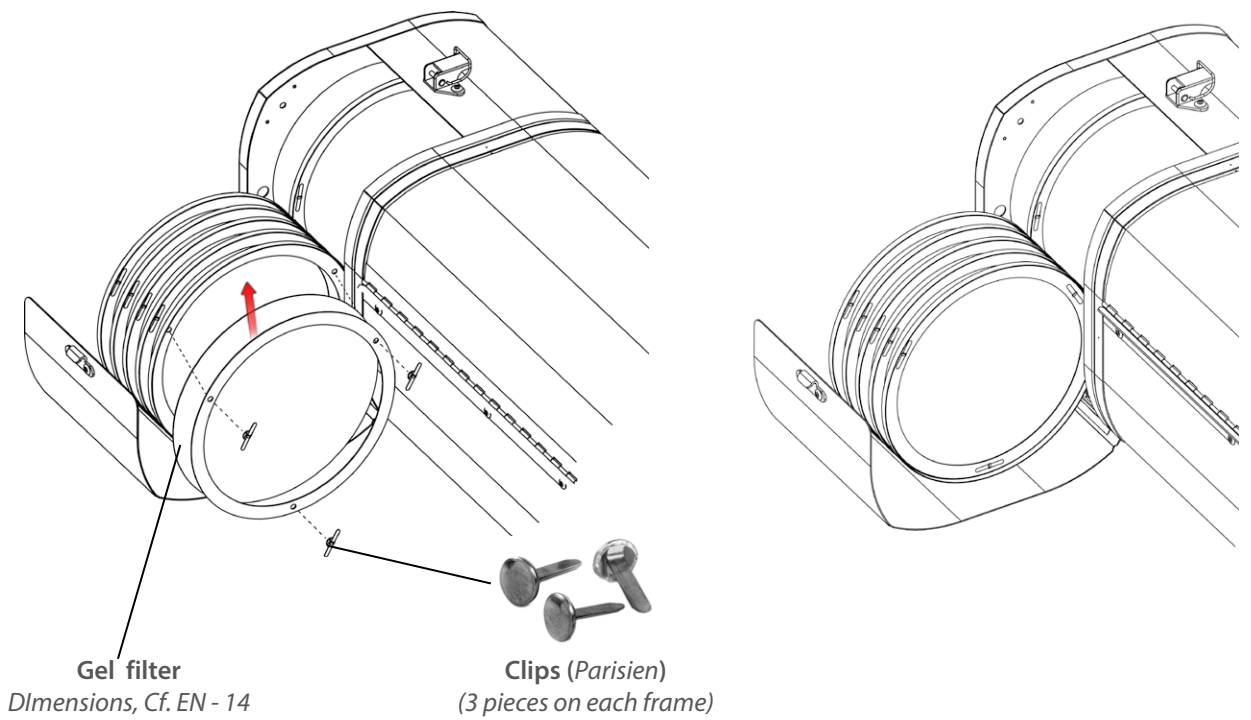

## 4.1 Light intensity

### 4.1.1 Range

• Dimming

0%



100%

### 4.1.2 Control

Remotely with DMX512-A protocol

Locally via rotary knob

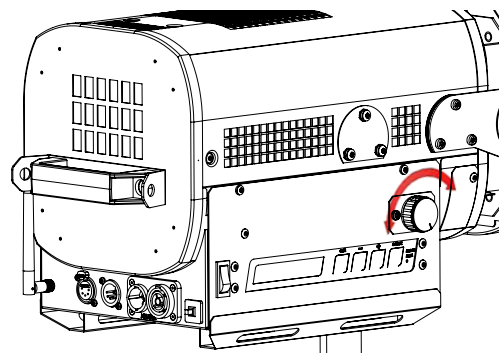
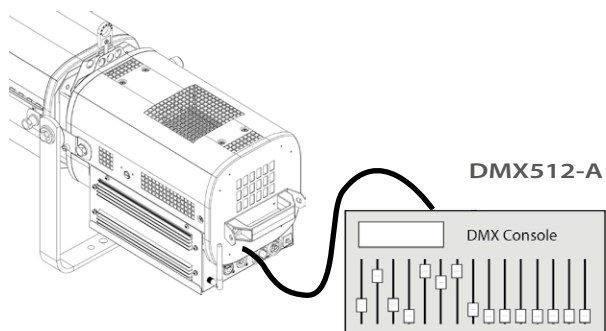

<b>HTP mode (Highest Takes Precedence):</b> Light output is the highest value of DMX512 command or local control
<b>Focus mode:</b> when standby screen displayed, Push Exit → Light output = 100% for 1 minute 2x times Exit → Light output = 0%
<b>Local control</b> → via rotary knob

### 4.1.3 Parameters

Resolution (MODE):

Mode	Resolution
8 bits	255 steps – 1 DMX channel
16 bits	65 535 steps – 2 DMX channels

Curve (LIGHT CURVE): Linear / Square

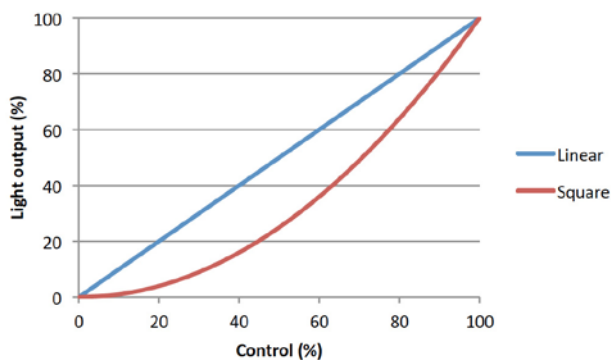

Smoothing (SMOOTHING) :

Mode	Smoothing
<i>Slow</i>	Slow transition between 2 levels – equivalent to 1000W filament
<i>Fast</i>	Fast transition between 2 levels – equivalent to 600W filament
<i>Without</i>	Deactivated – Very fast transitions

Master mode (MASTER CONTROL):

In order to supervise the operator from the console, a 3rd DMX channel is used: Master control.

This channel limits the maximum value of the dimmer shutter.

By using this function, it's possible to obtain synchronised fades with several spots or to give intensity limits (minimum and maximum) to the operator . Master is only active when DMX is detected.

DMX		Local	Light Output
8/16 bits	Master		
0 → 100%	100%	0%	0 → 100%
0 → 100%	50%	0%	0 → 50%
0%	100%	0 → 100%	0 → 100%
0%	50%	0 → 100%	0 → 50%
50%	100%	0 → 100%	50 → 100%
30%	80%	0 → 100%	30 → 80%

→ Mode required when simultaneous remote and local control are necessary  
(example: followspot)

## 4.2 Beam size adjustment

### 4.2.1 Range

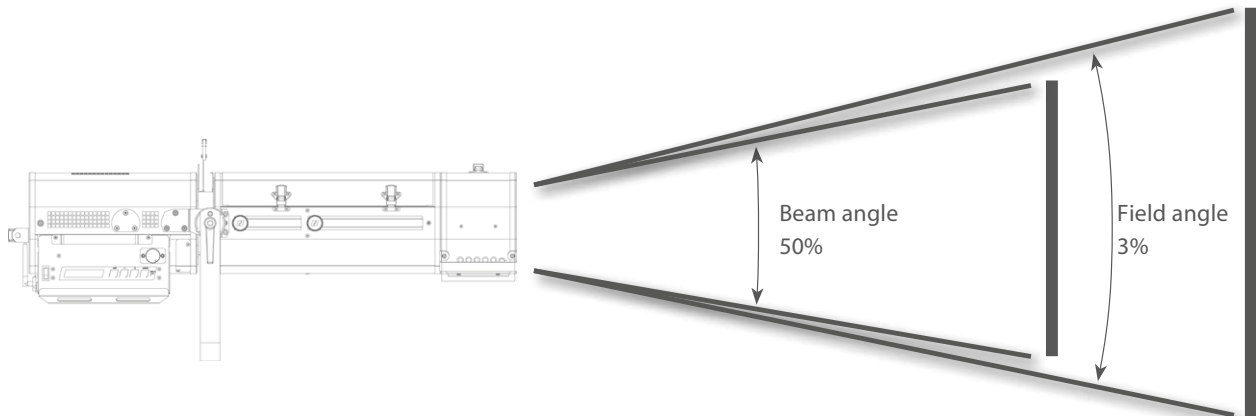

Model	Angles	Minimum angle	Maximum angle
1166	Beam angle	10.6°	15.5°
	Field angle	11°	22.1°

### 4.2.2 Control

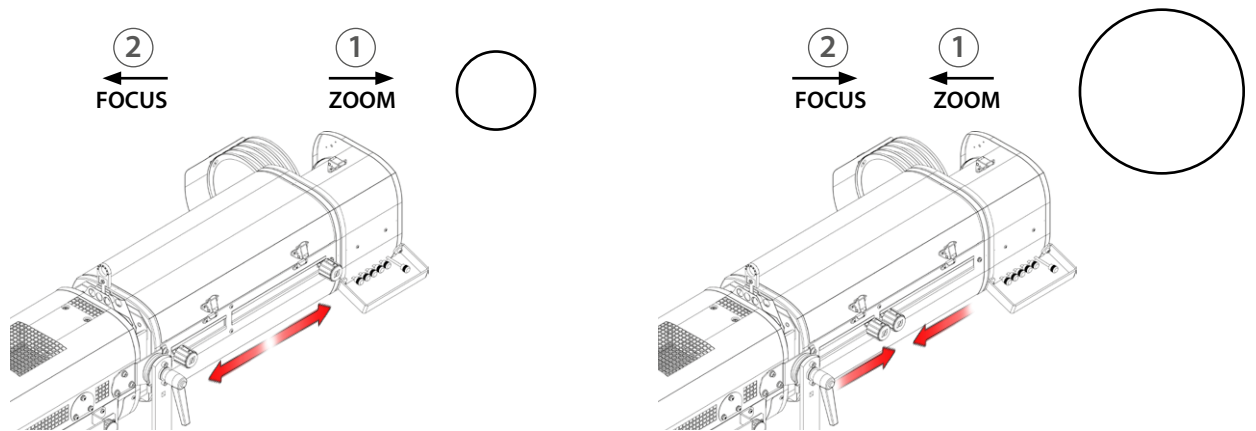

## 4.3 Strobe

### 4.3.1 Range

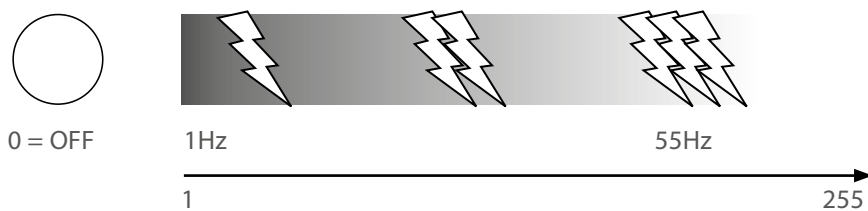

### 4.3.2 Control

Remotely with DMX512-A protocol

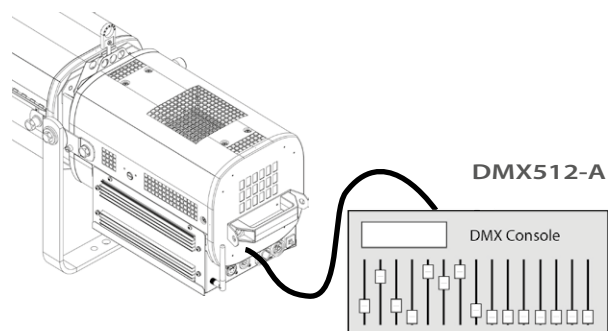

## 4.4 Pan / Tilt

### 4.4.1 Range

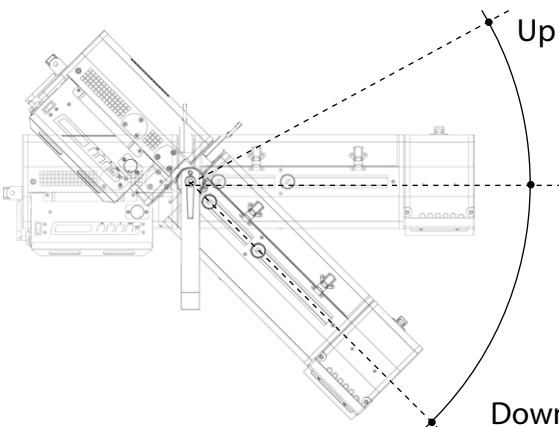
Function	Range
PAN	0 → 360°
TILT	 <p>Tilt up = 0 → 35° Tilt down = 0 → 65°</p>

### 4.4.2 Control

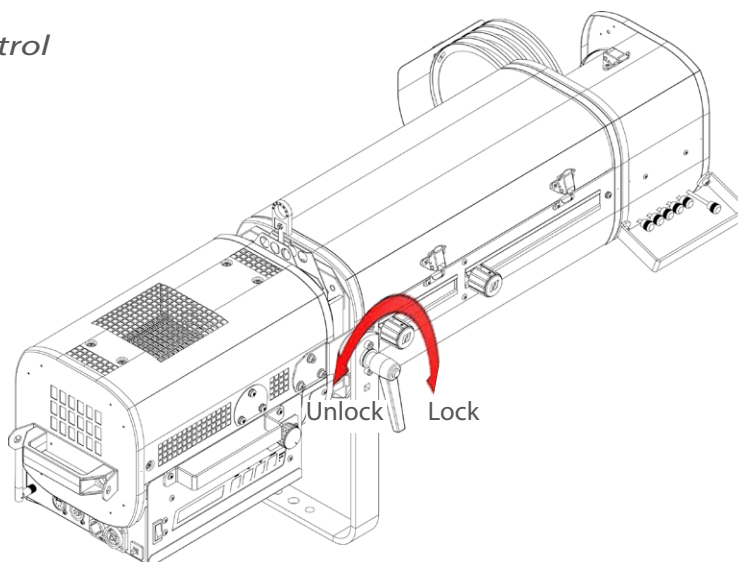

4.5 Iris

4.5.1 Range

- Irising

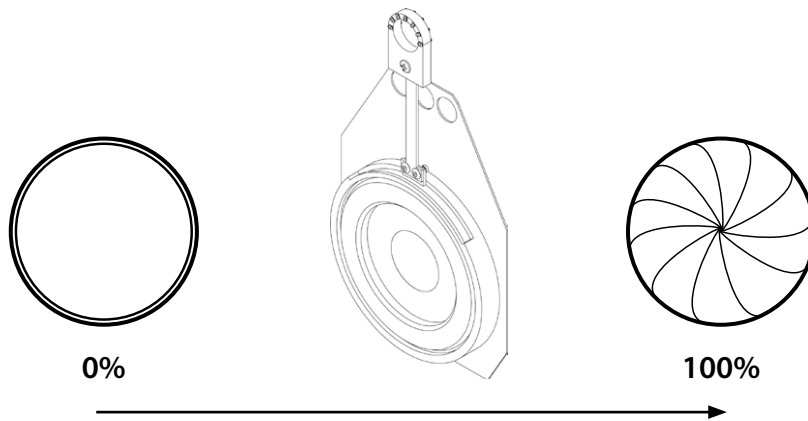

4.5.2 Control

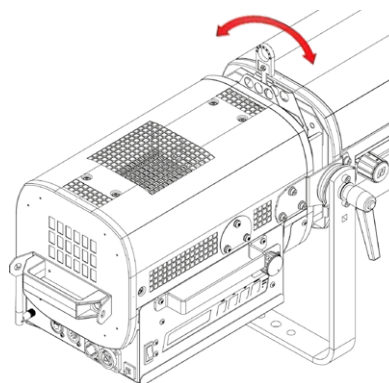

4.6 Gobo

4.6.1 Range

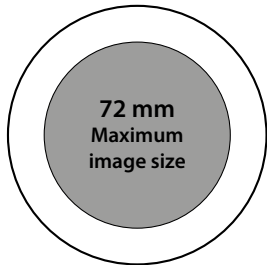
Type	Standard gobo - A size
Dimensions	<p style="text-align: center;"><b>100 mm</b></p>  <ul style="list-style-type: none"> <li>• Metal</li> <li>• Glass</li> <li>• Frosted glass</li> </ul> <p style="text-align: right;"><i>Values are in millimeters (mm)</i></p>
Installation	Cf. section: 3.3.2, page EN - 9

4.7 Colour

- Fixed colour: place dark colours towards the rear end.

4.7.1 Range

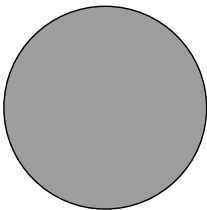
Type	Coloured gel filter
Dimension	<p style="text-align: center;"><b>165 mm</b></p> 
Installation	Cf. section: 3.3.3, page EN - 9

# 5 DMX Controls



## 5.1 Control board

### 5.1.1 Display and Controls

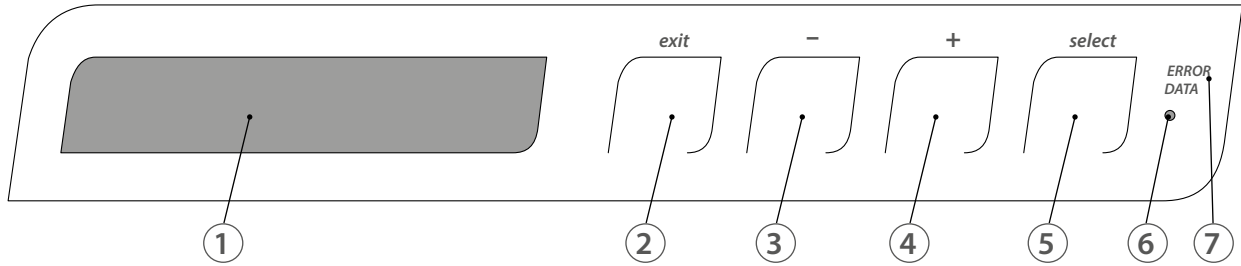

Function	
1	Display
2	Exit the current menu option and/or go back
3	Scrolls through menus and/or Decrease blinking data value
4	Scrolls through menus and/or Increase blinking data value
5	Enter the current menu option and/or valid
6	Hard CPU reset
7	DMX and system LED feedback

### 5.1.2 Menus and parameters

Please scan this QR-Code for the software menu or go to : [www.robertjuliat.com/productSearch.html](http://www.robertjuliat.com/productSearch.html) to find the latest version.



### 5.1.3 DMX chart

Mode	Theatre	Studio	Followspot	Direct DMX (variable white)
DMX ch.				
1	Dimmer (8 bit)	Dimmer Coarse (8 bit)	Dimmer Coarse (8 bit)	WW Coarse (8 bit)
2		Dimmer Fine (16 bit)	Dimmer Fine (16 bit)	WW Fine (16 bit)
3		CCT 0 → 255 : WW → CW	CCT 0 → 255 : WW → CW	CW Coarse (8 bit)
4		Strobe 0 : OFF ; 1 → 255 : SLOW → FAST	Strobe 0 : OFF ; 1 → 255 : SLOW → FAST	CW Fine (16 bit)
5			Master 0 → 255 : 0 → 100% (FULL)	Strobe 0 : OFF ; 1 → 255 : SLOW → FAST

### 5.1.4 Reset

- Reset to default settings:  
Menu: *Fixture Reset* → press *Select* → Yes & press *Select* to validate

### 5.1.5 Feedback information

- DMX and system LED feedback (see *display & controls* (7) Cf. EN-15):  
⇒ Green= DMX512 frame detected  
⇒ Red = Problem on DMX512 frame and/or system default – details available in the fixture status
- If DMX512 data lost, the following message is displayed:

**“Push select to reset DMX values”**

The last received DMX values are stored but it is possible to inactivate the current values by pressing the Select key (as well as the Master function) in order to get a total control of the fixture locally. When a DMX signal is detected, the DMX control is active again.

- ¥ signal indicates a wireless DMX:

Signal	Information
Switched off – no symbol	The fixture is not paired with a transmitter
Slow intermittent display	The fixture is paired with a transmitter but the DMX signal is not detected
Continuous display	The fixture is paired with a transmitter and the DMX signal is detected
Rapid intermittent display	Lost connection with the transmitter or in connection with the transmitter

## 6 Service

### 6.1 Preventive maintenance

#### 6.1.1 Frequency

General maintenance should be performed at least once a year or more frequently if the equipment is operated in adverse conditions (smoke, heat, humidity, touring, etc.).

#### 6.1.2 General cleaning

Remove dust from the unit (air vents, printed circuit boards, etc.).

During cleaning:



- LED is protected by a safety glass to avoid any contact.  
DO NOT spray directly onto the glass.
- Fan blades must be locked.

#### 6.1.3 General visual check

- No trace of heat.
- No loose contacts.
- No missing parts.
- Tighten mechanical assemblies (screws, bolts and nuts, ground connections, etc.).

#### 6.1.4 LED source



- Do not touch the surface of the LED source (no contact with your hands or any tools).
- Do not put compressed air directly on the source.
- Contact a certified RJ distributor in case of residuals or other objects located on the surface of the LED source.

### 6.1.5 Optics

The cleaning of optical parts (lenses) shall be carried out with solutions containing alcohol.

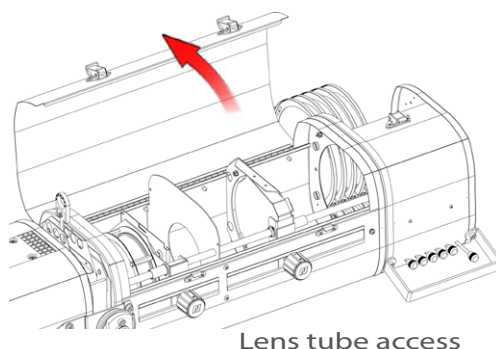

### 6.1.6 Analysis

If there is still a problem after the troubleshooting procedures (Cf. section 7), contact RJ distributor with the following information:

- Model, version and serial number of the product.
- Software version (available in menu Fixture Status → Version)
- Description of the problem.

### 6.1.7 LED reaction according to LED temperature

LED temperature	Fan
5°C → 65°C	Fan rotation at minimum level
65°C → 75°C	Fan rotation increases progressively
75°C → 90°C	Fan at maximum speed LED intensity dims to zero output (overheating protection) DMX and system LED feedback (7) is red

LED intensity dims to zero output (overheating protection).  
DMX and system LED feedback (7) is red and temperature is available in Fixture Status menu.

### 6.1.8 Thermal protection

In case of thermal protection start :

- Remove the LED compartment (Cf. 6.1.4).
- Control possible overheating indications.
- Reassemble the LED compartment.
- Reset the thermal protection by pressing the button.

### 6.1.9 Adjusting the maximum light output level

The maximum intensity level of the LED source can be adjusted through the fixture setup in order to have a consistent fixture fleet. The dimming level is then recalculated depending on the limitation.

### 6.1.10 Exploded view / Spare parts list

➔ Available on [www.robertyuliat.com](http://www.robertyuliat.com)

➔ Or on request through the Robert Juliat Service department [info@robertyuliat.fr](mailto:info@robertyuliat.fr)

## 7 Troubleshooting

### 7.1 General information

SYMPTOMS		POSSIBLE REASONS	SOLUTIONS	
Display OFF	Display switches on when button is pressed	Display auto off mode activated	Check the AUTO-OFF display in the <i>Fixture Setup</i>	
	Display still off when button is pressed	No power	Check : <ul style="list-style-type: none"> <li>• power</li> <li>• thermal protection</li> <li>• the power supply connector must be properly interlocked</li> </ul>	
System and data display ⑦ switched on in red (see page EN-15)		Problem with the DMX512 received signal and/or system default	Failure details are available in <i>Fixture Setup</i>	
The unit cannot be controlled via DMX (inactivated wireless DMX)	Data display ⑦ switched on in red	DMX protocol problem	Check data signal	The received data protocol can be checked in the <i>DMX Setup</i>
		Data cabling problem	Check cabling and data connectors	
	Data display ⑦ switched on in green	DMX address	Check the DMX address	
		The strobe is active and the channel value is void	The value must be at 0 in order to have the light intensity dimmed	
When using several units, dimming are not synchronized		Different <i>Resolution</i>	All the units must have the same mode	
		Different <i>Smoothing</i>		
		Different <i>Dimming curve</i>		
Light switches on when powered on		Manual value is operating when DMX is not connected	Local values must be at zero	
Light switches on when using the control board		Use of the Focus mode	Section 4.1.2	
Strobe function doesn't work		Strobe function inactive	Check that the selected mode allows the strobe function	
		Strobe function active	Control channel must be higher than 0	